

HATCHES

FORECASTLE DECK

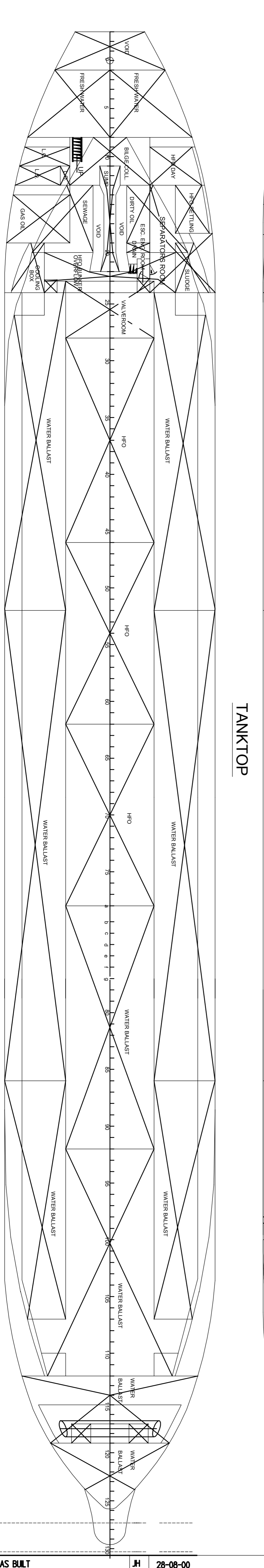
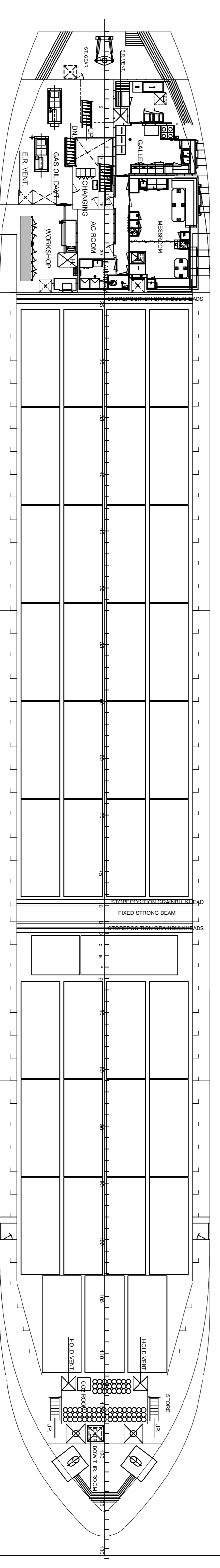
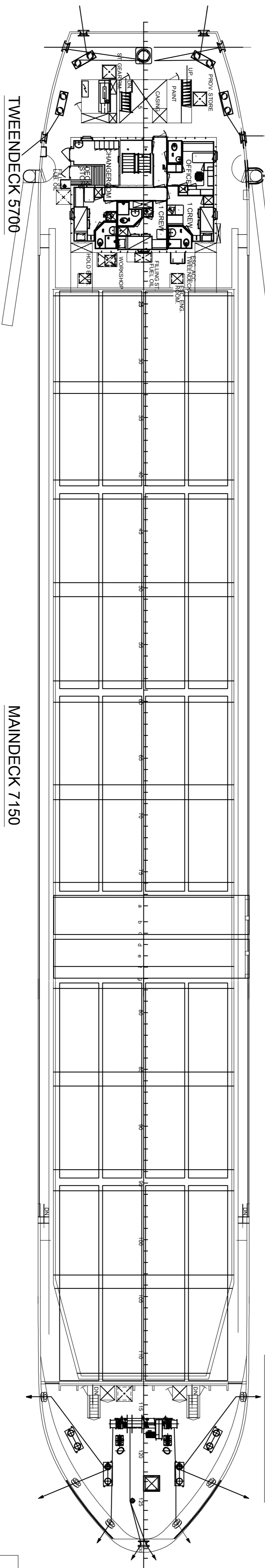
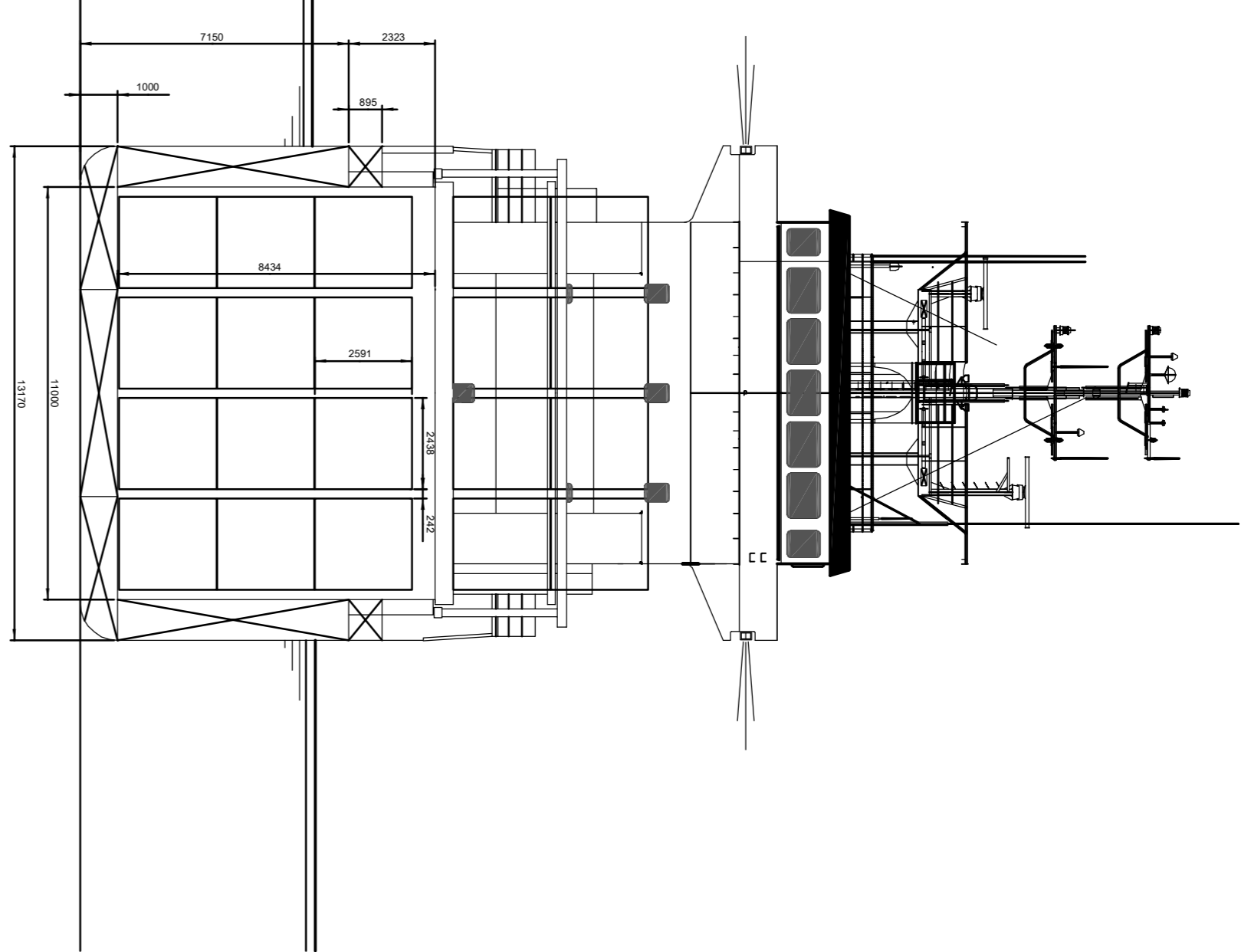

PRINCIPAL PARTICULARS

Length o.a.	96,16 M
Length b.p.p.	90,25 M
Breadth mid.	13,17 M
Depth mid.	7,15 M
Draught mid.	6,180 M
Deadweight	5010 T
Capacity:	
Capesize:	Hold
Heavy Fuel Oil incl day and settl.	appr. 6196 M3
Ballast Water	appr. 209 M3
Fresh Water	appr. 1727 M3
Gas Oil incl daytank aux. engines	appr. 41 M3
Gas Oil incl daytank aux. engines	appr. 37 M3
Containers:	
Hold	120 TEU
on Deck	104 TEU
Total	224 TEU
Ice class	1-C
Speed 90% MCR at 6,19 meter	appr. 12,0 KM
Engine output 100% MCR	2200 kW
Gross tonnage	2997 GT

D	AS BUILT	H	28-08-00
C	UPDATED	B	16-01-00
B	ARRANGEMENT RAISED DECK AT FS	A	14-10-99

Schepswaerweg 13
 PO Box 79 9600AB Hoogezand, HOLLAND
 Tel: 0596-380022 Fax: 0596-384863

1:150
 B. GRODT 01-07-99
 0793

GENERAL ARRANGEMENT

A B C D

0768 - 000 - 001